



**OPERATOR MANUAL**  
**UTAC™ Series**  
**Universal Thermal Acquisition Clip-On**



Nivisys Industries LLC  
400 S. Clark Drive  
Suite 105  
Tempe, AZ 85281 USA

480-970-3222 (tel)  
480-970-3555 (fax)  
info@nivisys.com  
www.nivisys.com

Export of the commodities described herein is strictly prohibited without a valid export license issued by the U.S. Department of State Office of Defense Trade Controls prescribed in the International Traffic in Arms Regulations (ITAR) Title 22, Code of Federal Regulation, Chapter 1, Subchapter M, Parts 120-130.

**Inside cover intentionally left blank.**

**OPERATOR  
MANUAL  
for**

**UTAC™ Series**

Universal Thermal Acquisition Clip-On

UTAC-32M™ (320 x 240, 35mm lens)

UTAC-32L™ (320 x 240, 60mm lens)

UTAC-64M™ (640 x 480, 35mm lens)

UTAC-64L™ (640 x 480, 60mm lens)

**ALL RIGHTS RESERVED**

This document contains information developed by Nivisys Industries, LLC. It has been prepared to instruct Nivisys customers in the proper care and operation of the equipment respective to this document.

Neither receipt nor possession thereof confers any right to reproduce or use, or disclose, in whole or in part, any such information without written authorization from Nivisys Industries, LLC.

Copyright © March 23, 2011.

**This page intentionally left blank.**

## **ADVISORY OVERVIEW**

The following description categorizes the level of risk associated with each cautionary statement displayed throughout the manual.

### **WARNING**

**HIGHLIGHTS AN OPERATION OR PROCEDURE WHICH, IF NOT STRICTLY OBSERVED, COULD RESULT IN INJURY TO OR DEATH OF PERSONNEL.**

### **CAUTION**

**HIGHLIGHTS AN OPERATION OR PROCEDURE WHICH, IF NOT STRICTLY OBSERVED, COULD RESULT IN DAMAGE TO OR DESTRUCTION OF EQUIPMENT OR LOSS OF MISSION EFFECTIVENESS.**

### **NOTE**

**HIGHLIGHTS AN ESSENTIAL OPERATION, PROCEDURE, CONDITION OR STATEMENT.**

**This page intentionally left blank.**

# TABLE OF CONTENTS

Advisory Overview	iii
Table of Contents	v
List of Figures	viii
List of Tables	ix
<b>CHAPTER 1: GENERAL INFORMATION</b>	<b>1-1</b>
1.1 Introduction	1-1
1.2 Equipment Description	1-1
1.3 Standard Kit Parts List	1-2
1.4 Standard Kit Parts Illustration	1-3
1.5 Optional Items List	1-4
1.6 Optional Items Illustration	1-5
1.7 System Performance and Data	1-6
<b>CHAPTER 2: PREPARATION FOR USE</b>	<b>2-1</b>
2.1 Introduction	2-1
2.2 Battery Precautions	2-1
2.3 Battery Installation	2-2
2.4 Coupling Hood Installation	2-2
2.5 35mm Lens Cover Installation	2-4
2.6 60mm Lens Cover Installation	2-5
2.7 Weapon Mount Installation	2-6
2.8 Attaching the UTAC to a Weapon	2-7
2.9 Installing the Remote Switch to the UTAC	2-10
2.10 Attaching the Remote Switch to the Weapon	2-12

# TABLE OF CONTENTS (CONT.)

<b>CHAPTER 3: OPERATING INSTRUCTIONS</b>	<b>3-1</b>
3.1 Introduction	3-1
3.2 Operating Precautions	3-1
3.3 Controls and Indicators	3-1
3.4 Powering ON the UTAC	3-3
3.5 Battery Indicator	3-4
3.6 Thermal Calibration	3-5
3.7 Range Focus Adjustment (Units with 60mm Lens)	3-6
3.8 Digital Zoom	3-7
3.9 Polarity (White-Hot/Black-Hot)	3-8
3.10 Display Brightness	3-8
3.11 Menu Activation and Use	3-9
3.12 Selecting Reticle Type	3-10
3.13 Removing Reticle	3-11
3.14 Adjusting Azimuth	3-11
3.15 Adjusting Elevation	3-14
3.16 Zeroing the UTAC as a Weapon Sight	3-16
3.17 Powering OFF the UTAC	3-17
3.18 Preparation for Storage	3-17
3.19 Use with the Remote Switch	3-18
<b>CHAPTER 4: MAINTENANCE INSTRUCTIONS</b>	<b>4-1</b>
4.1 Introduction	4-1
4.2 Preparing for Maintenance	4-1
4.3 Cleaning the UTAC	4-1
4.4 Cleaning the Optics	4-2
4.5 Checking for Damage and Corrosion	4-2

# TABLE OF CONTENTS (CONT.)

<b>CHAPTER 5: TROUBLESHOOTING</b>	<b>5-1</b>
5.1 Troubleshooting Procedures	5-1
<b>APPENDIX A: SPARE AND REPAIR PARTS LIST</b>	<b>A-1</b>
A.1 Introduction	A-1
A.2 Contact Information	A-1
A.3 Spare Parts List	A-1
<b>APPENDIX B: WARRANTY INFORMATION</b>	<b>B-1</b>

# LIST OF FIGURES

<b>FIGURE</b>	<b>DESCRIPTION</b>	<b>PAGE</b>
1-1	Standard Kit Parts Illustration	1-3
1-2	Optional Parts Illustration	1-5
2-1	Battery Installation	2-2
2-2	Hood Installation Alignment	2-3
2-3	Hood Installation Complete	2-3
2-4	35mm Lens Cover Installation	2-4
2-5	60mm Lens Cover Installation	2-5
2-6	Weapon Mount Installation	2-6
2-7	UTAC Mounted as a Clip-on	2-7
2-8	Slide Lock in Unlocked Position	2-8
2-9	Throw Lever Mount in Open Position	2-8
2-10	Throw Lever Closed	2-9
2-11	Throw Lever Mount Closed and Locked	2-9
2-12	Locknut Adjustment	2-10
2-13	Remote Switch Installation	2-11
2-14	Hook and Loop Installation	2-12
3-1	Controls and Indicators	3-2
3-2	Keypad Buttons	3-4
3-3	Battery Indicator Icons	3-4
3-4	Low Battery Indicator	3-5
3-5	Calibration	3-6
3-6	Range Focus Adjustment	3-7
3-7	Zoom Button	3-7
3-8	Polarity Button	3-8
3-9	Display Brightness Button	3-9
3-10	Menu Buttons	3-9
3-11	Menu Location	3-10
3-12	Reticle Types	3-11
3-13	Azimuth Selection	3-12
3-14	Azimuth Adjustment	3-13

## LIST OF FIGURES (CONT.)

<b>FIGURE</b>	<b>DESCRIPTION</b>	<b>PAGE</b>
3-15	Elevation Selection	3-14
3-16	Elevation Adjustment	3-15
3-17	Powering OFF the UTAC	3-17
3-18	Remote Switch	3-18

## LIST OF TABLES

<b>TABLE</b>	<b>DESCRIPTION</b>	<b>PAGE</b>
1-1	Standard Kit Parts List	1-2
1-2	Optional Items List	1-4
1-3	System Performance and Data	1-6
3-1	Controls and Indicators	3-3
3-2	Reticle Adjustment Per Click	3-16
5-1	Troubleshooting	5-1
A-1	Spare and Repair Parts List	A-1

**This page intentionally left blank.**

# CHAPTER 1:

## GENERAL INFORMATION

### 1.1 Introduction:

This manual provides operation and maintenance instructions for the Universal Thermal Acquisition Clip-on (UTAC). It also provides specifications and data on the performance of the weapon sight. To ensure the safety of the operator and the correct operation of the weapon sight, it is recommended that this manual is read carefully in its entirety before any deployment or field application.

### 1.2 Equipment Description:

The UTAC from Nivisys Industries represents the latest advancement in our series of thermal sights. The UTAC is an extremely rugged, compact, lightweight device. It provides detection and targeting capability during night and adverse weather conditions when used in front of existing day optics of the weapon.

The UTAC is easy to operate with its simple and intuitive controls. The uncooled VOx thermal detector draws very low power from two CR123 batteries, providing the operator with over 4 hours of continuous battery life.

When installed in front of a boresighted day optic, the UTAC provides targeting capabilities with the same reticle and shooting position as daytime operations. The UTAC may also be used as a stand alone thermal weapon sight. User selected reticles and azimuth/elevation adjustments make targeting simple and fast for quick response.

The remote control switch provides increased flexibility for the user, integrating the sight and the weapon. With the control pad in an ideal location, such as the fore grip, the user can now control the thermal sight with no change to normal weapon handling.

### 1.3 Standard Kit Parts List:

The standard UTAC kit comes with the items listed in the following table.

Item	Part No.	Description	Qty.
1	4200-001 4210-001 4300-001 4310-001	UTAC-32M (320 x 240, 35mm lens) UTAC-32L (320 x 240, 60mm lens) UTAC-64M (640 x 480, 35mm lens) UTAC-64L (640 x 480, 60mm lens)	1
2	1407-500	Soft Carrying Case	1
3	1407-501	Shoulder Strap	1
4	580-0002-0	Battery, CR123 Lithium	2
5	170-12	Cleaning Kit	1
6	3250-000	RS-16, Remote Switch	1
7	830-0079-0	Operator Manual, UTAC	1
8	830-0089-0	Quick Reference Guide, UTAC	1
9	790-0015-0	Mount Adjustment Tool	1

**Table 1-1 Standard Kit Parts List**

#### 1.4 Standard Kit Parts Illustration:

The illustration below is provided for quick identification of the standard parts of the UTAC kit.

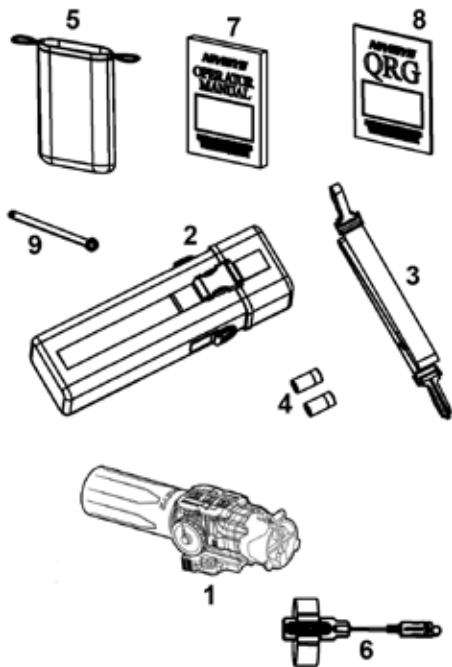

Figure 1-1 Standard Kit Parts Illustration

### 1.5 **Optional Items List:**

The UTAC is compatible with the following optional items and accessories listed in the following table.

<b>Item</b>	<b>Part No.</b>	<b>Description</b>
1	3260-000	External Video Module
2	7B257-2F	Shipping/Storage Case
3	A3144306	Neck Cord

**Table 1-2 Optional Items List**

## 1.6 Optional Items Illustration:

The illustration is provided as a visual key to optional items that can be used with the standard UTAC.

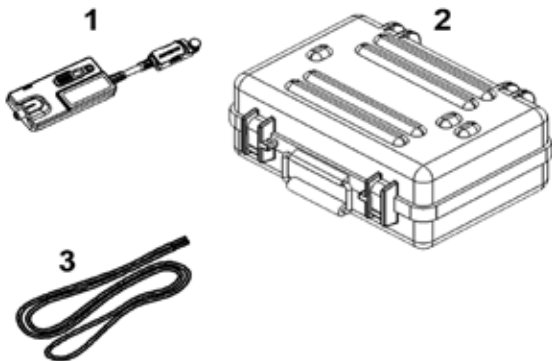

Figure 1-2 Optional Parts Illustration

## 1.7 System Performance and Data:

The table below lists the technical specifications and data of the UTAC system. The data contained herein is subject to change without notice.

ITEM	LIMITS			
<b>Electrical</b>				
Power Source	Battery (3.0V DC max.)			
Battery Requirements	CR123 Lithium (2ea.)			
Battery Life	>4 hrs @ 21°C (70°F)			
<b>Physical</b>				
	<b>-32M</b>	<b>-64M</b>	<b>-32L</b>	<b>-64L</b>
Overall Dimensions (L x H x W)	18.1 x 7.8 x 7.3cm (7.1 x 3.0 x 2.9")		22.5 x 8.5 x 9.5cm (8.6 x 3.3 x 3.7")	
Weight (with batteries)	550g (19.4 oz)		686g (23.9 oz)	
<b>Environmental</b>				
Operating Temperature	-20°C to +50°C			
Storage Temperature	-20°C to +70°C			

**Table 1-3 System Performance and Data**

<b>Optical</b>				
	<b>-32M</b>	<b>-64M</b>	<b>-32L</b>	<b>-64L</b>
Sensor Resolution	320 x 240	640 x 480	320 x 240	640 x 480
Sensor	Vanadium Oxide (VOx) Microbolometer Uncooled 30Hz frame rate			
Magnification	1.0X			
Thermal Sensitivity	<50mK			
Spectral Response	7 – 14 $\mu$ m			
Video Output (Optional)	NTSC/PAL Composite Video			
Objective Lens	35mm, f/1.4	35mm, f/1.4	60mm, f/1.25	60mm, f/1.25
Field of View	13° (H) x 10° (V)	18° (H) x 13° (V)	8° (H) x 6° (V)	10° (H) x 8° (V)
Reticle Adjustment per click at 100yds (2X Zoom mode)	1.1"	1.5"	0.6"	0.9"

**Table 1-3 System Performance and Data, (cont.)**

**This page intentionally left blank.**

## CHAPTER 2: PREPARATION FOR USE

### 2.1 Introduction:

This section contains instructions for installing and attaching various components and accessories to the UTAC for operation under normal conditions.

### 2.2 Battery Precautions:

#### **WARNING**

**DO NOT MIX OLD AND NEW BATTERIES.  
DO NOT MIX BRANDS OF BATTERIES. DO  
NOT MIX DISPOSABLE AND RECHARGEABLE  
BATTERIES. FAILURE TO FOLLOW THESE  
INSTRUCTIONS COULD RESULT IN DEATH,  
INJURY OR IMPOSITION OF LONG-TERM  
HEALTH HAZARDS.**

#### **WARNING**

**INSPECT BATTERIES FOR BULGING PRIOR  
TO USE. IF THE BATTERY SHOWS SIGNS OF  
BULGING, DO NOT USE.**

#### **WARNING**

**DO NOT HEAT, PUNCTURE, SHORT CIRCUIT,  
ATTEMPT TO RECHARGE OR OTHERWISE  
TAMPER WITH THE BATTERIES. TURN OFF  
THE UTAC IF THE BATTERY COMPARTMENT  
BECOMES UNDULY HOT. IF POSSIBLE, WAIT  
UNTIL THE BATTERIES HAVE COOLED  
BEFORE REMOVING THEM.**

## **CAUTION**

### **OBEY THE BATTERY MANUFACTURER'S DIRECTIONS FOR BATTERY DISPOSAL.**

#### **2.3 Battery Installation:**

The electronic circuit is powered by two (2) Lithium CR123 cells. Install the batteries as follows.

1. Remove the battery cap by turning it counter-clockwise.
2. Check to ensure the orange o-ring is present and undamaged. Replace o-ring if necessary.
3. Insert batteries into the battery compartment, negative (-) ends first, positive ends toward the battery cap.
4. Replace battery cap, turning it clockwise until a stop occurs. When fully engaged the orange o-ring should no longer be visible.

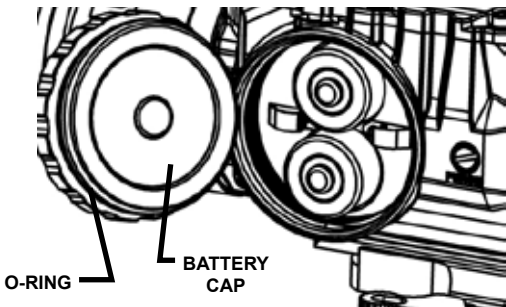

**Figure 2-1 Battery Installation**

#### **2.4 Coupling Hood Installation:**

When the UTAC is used as a clip-on sight, the hood blocks out stray light between the two optical sights. When the UTAC is

used as a hand held thermal device, the hood may be folded back and used as an eyecup. Perform the following procedure to install the hood onto the collimating lens of the UTAC.

1. Hold the hood near the circular opening.
2. Place the hood over the large beveled diameter of the collimating lens.
3. Push and stretch the hood completely over the entire collimating lens.
4. Rotate the hood so that “Nivisys” is located on top of the unit.



**Figure 2-2 Hood Installation Alignment**

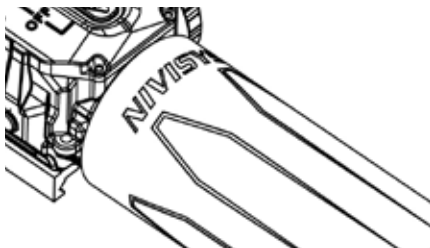

**Figure 2-3 Hood Installation Complete**

## 2.5 35mm Lens Cover Installation:

The UTAC-32M and UTAC-64M are issued with the lens covers pre-installed. In the event installation or re-installation is necessary, perform the following procedure.

1. Close the lens cover assembly.
2. Ensure the lens cover catch is facing up.
3. Press the lens cover assembly onto the objective lens.
4. Gently rock the lens cover assembly back and forth while continuing to press firmly onto the objective lens.
5. The lens cover is fully seated as the lens cover base and the TAG body meet.

### NOTE

**PROPER INSTALLATION OF THE LENS COVER MATCHES THE PROFILE OF THE LENS COVER BASE TO THE PROFILE OF THE UTAC BODY.**

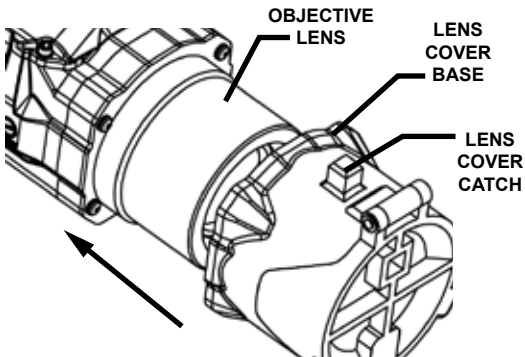

**Figure 2-4 35mm Lens Cover Installation**

## 2.6 60mm Lens Cover Installation:

The UTAC-32L and UTAC-64L are issued with the lens covers pre-installed. In the event installation or re-installation is necessary, perform the following procedure.

1. Stretch the lens cover retainer over the lens cover catch.
2. Push the lens cover retainer until seated on the lens cover retainer catch.
3. Push the lens cover over the lens cover catch.

### NOTE

**THE 60MM LENS CAN BE ROTATED FOR OPERATOR PREFERENCE.**

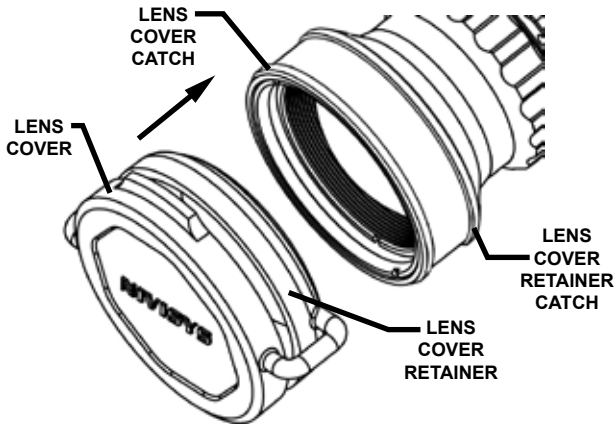

Figure 2-5 60mm Lens Cover Installation

## 2.7 **Weapon Mount Installation:**

The UTAC is issued with the throw lever mount pre-installed. When installation or reinstallation is necessary, perform the following procedure.

1. Arrange the weapon mount v-block so that it sits in the receiving v-block of the weapon mount adapter.

### **NOTE**

**WHEN THE WEAPON MOUNT IS CORRECTLY ATTACHED, THE THROW LEVER WILL BE ON THE BATTERY CAP SIDE OF THE UTAC.**

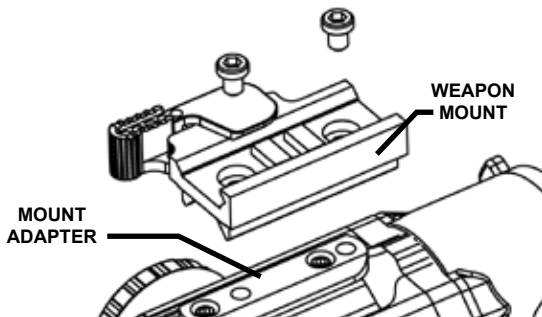

**Figure 2-6 Weapon Mount Installation**

2. Using a 3/32" hex key, fasten the throw lever mount onto the mount adapter using 2 ea. 10-24 x .375" socket low-head cap screw. (Loctite 242 is recommended.)
3. Ensure that the mount is securely fastened to the weapon before firing.

## 2.8 Attaching the UTAC to a Weapon:

To attach the UTAC to a MIL-STD-1913 rail system perform the following procedure.

### **NOTE**

**WHEN USING AS A CLIP-ON, MOUNT THE UTAC IN FRONT OF THE DAY SIGHT. TO ENSURE THE BEST PERFORMANCE, THE UTAC SHOULD BE MOUNTED AS CLOSE AS POSSIBLE TO THE DAY SIGHT WITHOUT TOUCHING.**

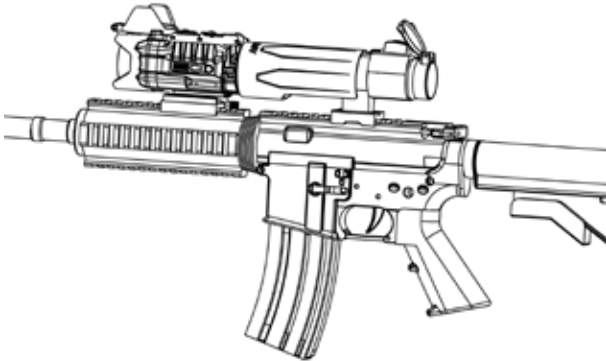

**Figure 2-7 UTAC Mounted as a Clip-on**

1. Ensure that the mount is securely fastened to the UTAC.
2. Set the slide lock to the unlocked position by pulling it back.

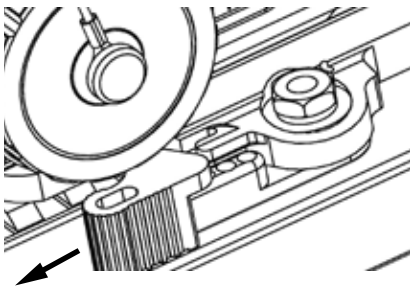

**Figure 2-8 Slide Lock in Unlocked Position**

3. Rotate the throw lever mount to the open position.

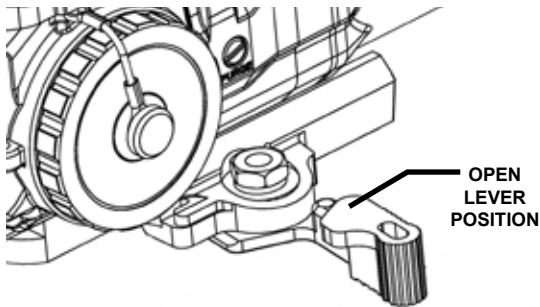

**Figure 2-9 Throw Lever in Open Position**

4. Place the UTAC on the rail system of the weapon so that it seats squarely on the rail.
5. Rotate the throw lever to the closed position.

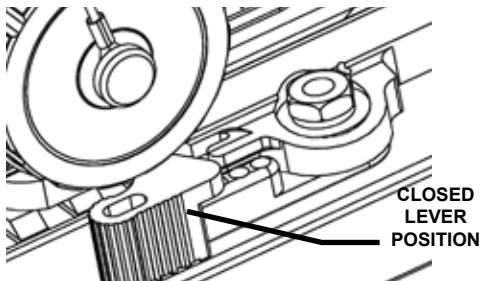

**Figure 2-10 Throw Lever Closed**

6. Secure the slide lock to the locked position by pushing it forward.

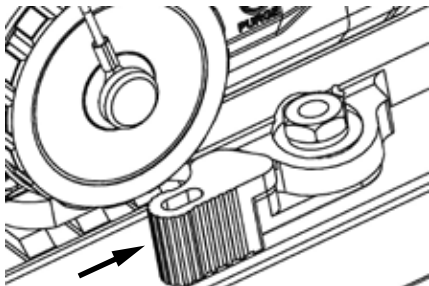

**Figure 2-11 Throw Lever Mount Closed and Locked**

7. If needed, tighten the tension of the locking lever with the provided mount adjustment tool. Turning the locknut clockwise makes it more difficult to open or close the

levers. Turning the locknut counter-clockwise makes lever positioning easier.

**NOTE**

**LOCKNUT REQUIRES ONLY SLIGHT  
MOVEMENT FOR TENSION ADJUSTMENT.**

**CAUTION**

**NEVER REMOVE THE LOCKNUT.**

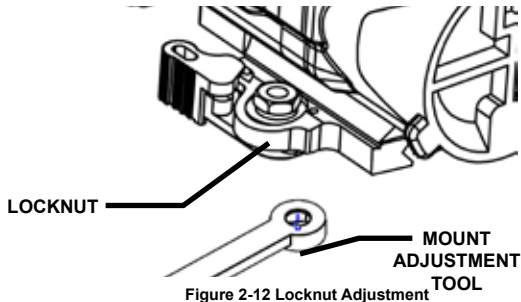

Figure 2-12 Locknut Adjustment

## 2.9 Installing the Remote Switch to the UTAC:

The RS-16 is a 16" remote switch that is issued standard to the UTAC kit. Nivisys offers the remote switch in different lengths for various weapon and operational requirements. To install the remote switch perform the following procedure:

**CAUTION**

**THE RS-16 REMOTE SWITCH IS NOT  
DESIGNED FOR IMMERSION OR  
UNDERWATER OPERATIONS.**

**CAUTION**

**ENSURE THAT THERE IS NO WATER, DUST OR DEBRIS IN THE CONNECTOR BEFORE ATTACHING THE REMOTE SWITCH.**

**NOTE**

**THE RS-16 CAN BE INSTALLED WHEN THE UTAC IS EITHER ACTIVATED OR DEACTIVATED.**

1. Lift and turn the hot shoe dust cover so that it is out of the way of the connector.
2. Align the remote switch exposed connector and engage thumbscrew to the threads on the UTAC body.
3. Screw the thumb screw into the thermal device about one (1) full turn so that the threads are engaged.
4. Push the remote switch connector into the thermal device.
5. Turn the thumb screw until a stop is reached or finger tight. It may be necessary to push in the remote switch connector once more during this step.

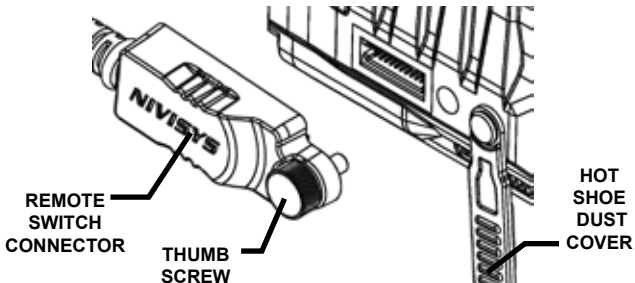

**Figure 2-13 Remote Switch Installation**

## 2.10 Attaching the Remote Switch to the Weapon:

The remote switch comes with the hook and loop tape preinstalled. When replacement is necessary, perform the following procedure.

1. Determine the best placement of the remote switch to the weapon.
2. Starting from the label side, feed the hook and loop tape into one of the slots in the keypad housing.
3. Fold approximately two (2) inches of the hook and loop tape onto itself and press firm.
4. Place the keypad housing on the weapon so that its cord travels onto the weapon heading toward the UTAC.

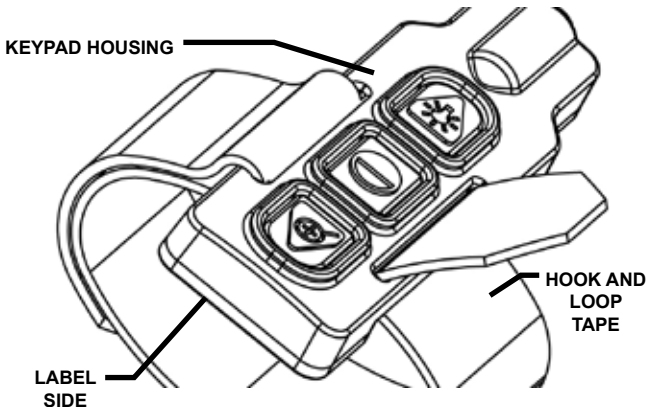

Figure 2-14 Hook and Loop Installation

**NOTE**

**ENSURE THAT THE SMOOTH SIDE FACES THE  
BUTTONS OF THE KEYPAD HOUSING SO THE  
HOOK AND LOOP CAN ADHERE TO ITSELF  
WHEN FOLDED OVER.**

5. Wrap the loose hook and loop tape around the weapon and feed the tape through the remaining open slot in the keypad housing.
6. Cinch tight and fold the hook and loop tape back onto itself.
7. Trim any excess.
8. Check for a secure attachment before use.

**CAUTION**

**REMOVE SLACK IN THE CORD TO PREVENT  
SNAG HAZARDS.**

**This page intentionally left blank.**

# CHAPTER 3:

## OPERATING INSTRUCTIONS

### 3.1 Introduction:

This chapter contains instructions for the safe operation of the UTAC under normal circumstances and environments.

### 3.2 Operating Precautions:

#### **CAUTION**

**THE THERMAL FOCAL-PLANE ARRAY  
UTILIZED WITHIN THE UTAC IS  
SENSITIVE TO EXPOSURE TO EXTREMELY  
HIGH LEVELS OF RADIANT FLUX. NEVER  
EXPOSE THE UTAC, EITHER POWERED OR  
UN-POWERED, DIRECTLY TO THE SUN OR  
ANY OTHER SOURCE OF RADIANT FLUX  
THAT THE HUMAN EYE CANNOT TOLERATE.**

#### **CAUTION**

**KEEP THE OBJECTIVE LENS COVER CLOSED AT  
ALL TIMES WHEN THE UTAC IS NOT IN USE.**

#### **NOTE**

**INADVERTENT SUN DAMAGE  
IS NOT CONSIDERED A DEFECT  
IN MATERIAL OR WORKMANSHIP,  
AND IS NOT COVERED  
IN THE PRODUCT WARRANTY.**

### 3.3 Controls and Indicators:

The controls and indicators for the UTAC are shown in Figure 3-1 and are described in Table 3-1.

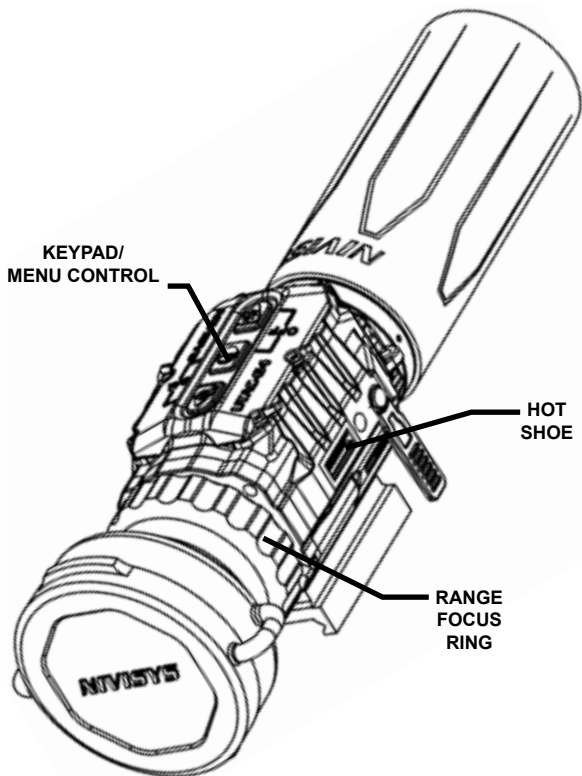

**UTAC-64L SHOWN**

**Figure 3-1 Controls and Indicators**

<b>Control and Indicators</b>	<b>Functions</b>
Keypad/ Menu Control	Switches unit ON or OFF. Activates Calibration, Polarity, Display Brightness and Digital Zoom. Controls Internal Menu System such as reticle selection, azimuth and elevation adjustment.
Battery Indicator (not shown)	Icon located in the eyepiece display that shows battery life of the system.
Range Focus Ring	Adjusts the focus of the viewed scene from 2m to infinity. Available in the UTAC-32L and UTAC-64L models only.
Hot Shoe	Controls the interface between the UTAC and accessories such as the RS-16 (remote switch) and the X-VID (external power and video).

**Table 3-1 Controls and Indicators**

### **3.4 Powering ON the UTAC:**

During activation, the circuit will energize and the start up screen will appear for a few seconds in the display.

To power ON the UTAC perform the following procedure:

1. Close the objective lens cover.
2. Press and hold any of the three keypad buttons for at least one second.

#### **NOTE**

**THE OBJECTIVE LENS COVER MUST BE CLOSED DURING START UP TO ALLOW THE CALIBRATION OF THE SYSTEM. CALIBRATION IS COMPLETE WITHIN TWO SECONDS OF START UP.**

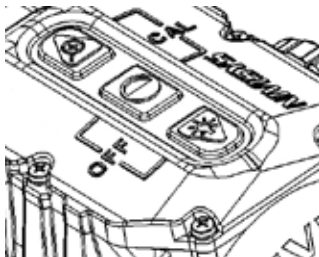

Figure 3-2 Keypad Buttons

**NOTE**

**WHEN THE REMOTE SWITCH IS ATTACHED,  
THE UTAC CAN ONLY BE POWERED ON  
THROUGH THE KEYPAD ON THE UTAC.  
ALL OTHER KEYPAD FUNCTIONS CAN BE  
EXECUTED USING THE REMOTE SWITCH.**

**3.5 Battery Indicator:**

To monitor available battery power, note the battery icon in the lower right hand quadrant of the eyepiece display. When battery life is low, a flashing low battery indicator will appear near the center of the eyepiece display.



Figure 3-3 Battery Indicator Icons

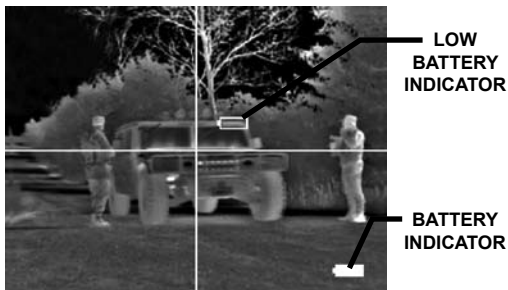

Figure 3-4 Low Battery Indicator

**NOTE**

**WHEN THE FLASHING LOW BATTERY INDICATOR APPEARS, THE UNIT HAS APPROXIMATELY 5 MINUTES OF BATTERY LIFE BEFORE AUTOMATIC SHUTDOWN.**

Two conditions determine the length of time the UTAC will operate on a set of batteries:

1. The brightness setting on the display.
2. The temperature at which the unit operates.

### **3.6 Thermal Calibration:**

The UTAC features shutterless core technology. For this reason, the lens cover of the unit must be used to calibrate the system. Calibration gives the user the clearest picture possible. To calibrate the system, perform the following procedure.

1. Close the lens cover.
2. Simultaneously press the Zoom and Polarity buttons.

The unit will automatically perform an initial calibration at power up. For this reason, it is necessary to keep the lens cover closed for a minimum of 2 seconds at power up. A second calibration is suggested at 30 seconds after power. This allows the thermal sensor to adjust to the surrounding temperatures. Additional calibrations may be required as surrounding temperature changes or any time a fixed, non-uniform shading appears on the display screen.

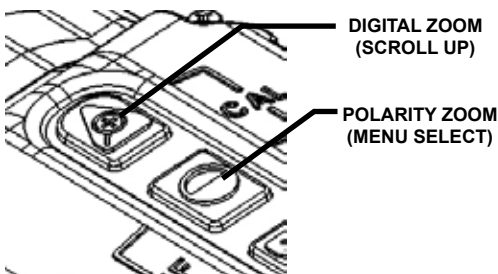
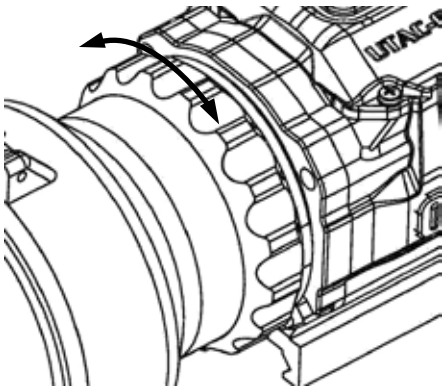

Figure 3-5 Calibration

### 3.7 Range Focus Adjustment (Units with 60mm Lens):

The range focus ring is used to focus the objective lens for objects viewed at varied distances. Rotate the range focus ring counter-clockwise for distant objects up to infinity. Rotate the range focus ring clockwise for close objects up to 2 meters.



**Figure 3-6 Range Focus Adjustment**

### **3.8 Digital Zoom:**

The UTAC is a 1X system. Press the Zoom button to electronically zoom the output to 2X. Press the button again to return to basic 1X magnification.



**Figure 3-7 Zoom Button**

### 3.9 Polarity (White-Hot/Black-Hot):

The UTAC Polarity button determines one of two viewing modes to identify environmental temperature differences: HOT temperatures are seen as WHITE on the screen or HOT temperatures are seen as BLACK on the screen. Press the Polarity button to toggle between the viewing modes.



Figure 3-8 Polarity Button

### 3.10 Display Brightness:

When the system is first turned on, the unit activates white-hot with a midrange display brightness setting. The unit has 12 brightness settings for white-hot and 12 brightness settings for black-hot; totalling 24 settings. When adjusting the brightness, each depression of the Display Brightness button will increase the level of intensity. A brightness level number will appear in the field of view.

#### **NOTE**

**AFTER THE UNIT REACHES ITS MAXIMUM BRIGHTNESS SETTING IT WILL CYCLE BACK TO ITS LOWEST SETTING.**

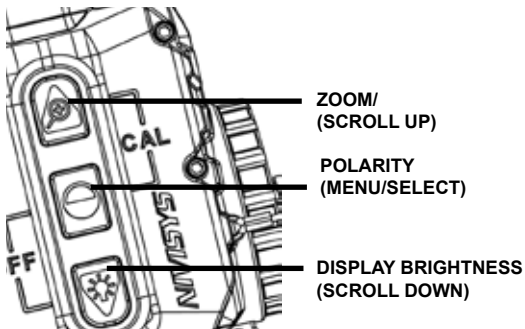

**Figure 3-9 Display Brightness Button**

### **3.11 Menu Activation and Use:**

To activate Menu Mode:

1. Press and hold the Polarity (Menu/Select) button until the menu appears on upper left portion of the display screen.
2. Use the Zoom (Scroll Up) and Display Brightness (Scroll Down) buttons to scroll through the menu items.
3. The Polarity (Menu/Select) button becomes the “select” tool.



**Figure 3-10 Menu Buttons**



**Figure 3-11 Menu Location**

### **3.12 Selecting Reticle Type:**

Installed in front of a boresighted day optic, the UTAC shares reticle of the day optic. However, when the UTAC is used as a stand alone thermal weapon sight, an internal reticle is available. To choose a specific reticle perform the following:

#### **NOTE**

**THE UTAC WILL START-UP WITHOUT A RETICLE DISPLAYED. IN ORDER TO SELECT AND DISPLAY A RETICLE, PERFORM THE FOLLOWING.**

1. Press and hold the Polarity (Menu/Select) button on the UTAC keypad until the menu appears in the top left hand corner.
2. Scroll until “TYPE” is highlighted.
3. Press the Polarity (Menu/Select) button to select “TYPE”
4. Scroll until desired reticle appears in display.
5. Press the Polarity (Menu/Select) button to exit “TYPE” function.
6. Press the Polarity (Menu/Select) button again to exit menu mode.



Figure 3-12 Reticle Types

**NOTE**

**RETICLE WILL AUTOMATICALLY CHANGE BLACK/WHITE DEPENDING ON BACKGROUND TARGET TO GIVE BEST CONTRAST.**

**3.13 Removing Reticle:**

To remove the reticle from the display screen, perform the following:

1. Press and hold the Polarity (Menu/Select) button on the UTAC keypad until menu appears in top left hand corner.
2. Scroll until “ON/OFF” is highlighted.
3. Press the Polarity (Menu/Select) button to select. The reticle will disappear.
4. Press Polarity (Menu/Select) button again to exit menu mode.

**NOTE**

**THE RETICLE WILL ALSO BE REMOVED FROM THE DISPLAY BY POWERING THE UTAC OFF AND BACK ON.**

**3.14 Adjusting Azimuth:**

To adjust the azimuth within the menu system of the UTAC, perform the following:

**CAUTION**  
**ALL BORESIGHT AND RETICLE  
ADJUSTMENTS MUST BE PERFORMED IN  
THE ZOOM MODE ONLY.**

**NOTE**  
**THE “DOT” RETICLE RETAINS AN  
INDEPENDENT BORE SIGHT.**

1. Press and hold the Polarity (Menu/Select) button on the keypad until the menu appears in top left hand corner.
2. Scroll until “AZIMUTH” is highlighted.
3. Press the Polarity (Menu/Select) button to select “AZIMUTH”.



**Figure 3-13 Azimuth Selection**

4. A master cross-hair with indices will appear IN ADDITION TO the reticle location. The distance between each index mark represents 20 pixels on the display. The reticle can be moved at 1 pixel intervals or scrolled across the screen by holding the button down.

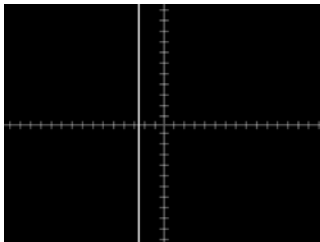

**Figure 3-14 Azimuth Adjustment**

5. Scroll up to move the reticle to the right to the desired position.

**NOTE**

**MOVING THE RETICLE TO THE RIGHT HAS THE SAME RESULT AS MOVING THE MEAN POINT OF IMPACT (MPI) TO THE LEFT.**

6. Scroll down to move the reticle to the left to the desired position.

**NOTE**

**MOVING THE RETICLE TO THE LEFT HAS THE SAME RESULT AS MOVING THE MPI TO THE RIGHT.**

7. Once satisfied with the azimuth position of reticle, press Polarity (Menu/Select) button to exit and store the “AZIMUTH” selection. The menu will default to “EXIT.”
8. Press the Polarity (Menu/Select) button to exit the menu or scroll to another desired tab on the menu.

### 3.15 Adjusting Elevation:

To adjust the elevation within the menu system of the UTAC, perform the following:

#### **CAUTION**

**ALL BORESIGHT AND RETICLE ADJUSTMENTS MUST BE PERFORMED IN THE ZOOM MODE ONLY.**

#### **NOTE**

**THE “DOT” RETICLE RETAINS AN INDEPENDENT BORE SIGHT.**

1. Press and hold Polarity (Menu/Select) button on keypad until menu appears in top left hand corner.
2. Scroll until “ELEVATION” is highlighted.



**Figure 3-15 Elevation Selection**

3. Press the Polarity (Menu/Select) button to select “ELEVATION”.
4. A master cross-hair with indices will appear IN ADDITION TO the reticle location. The distance between each index

mark represents 20 pixels on the display. The reticle can be moved at 1 pixel intervals or scrolled across the screen by holding the button down.

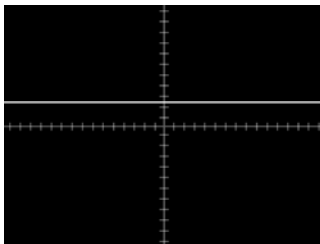

**Figure 3-16 Elevation Adjustment**

5. Scroll up to move the reticle up to desired position.
6. Scroll down to move the reticle down to the desired position.

**NOTE**

**MOVING THE RETICLE UP HAS THE SAME RESULT AS MOVING THE MPI DOWN.**

**NOTE:**

**MOVING THE RETICLE DOWN HAS THE SAME RESULT AS MOVING THE MPI UP.**

7. Once satisfied with the elevation position of the reticle, press the center (Menu/Select) button to exit and store the “ELEVATION” selection. The menu will default to “EXIT.”
8. Press the center (Menu/Select) button to exit the menu or scroll to another desired tab on the menu.

### 3.16 Zeroing the UTAC as a Weapon Sight:

For monocular performance with the UTAC it is necessary to align the sight with the weapon. This is referred to as “zeroing.” To zero the UTAC, perform the following:

1. Fix a thermal target at 25 meters distance. Ensure a sufficient thermal contrast is viewed through the UTAC before continuing.
2. Ensure that the weapon mount is securely fastened to the UTAC so there is no movement.
3. Securely fasten the UTAC to the weapon so there is no movement.
4. Power ON the UTAC.
5. Select the Digital Zoom mode.
6. Select a reticle type.
7. Adjust the brightness of the display to provide a good contrast between the target and reticle image.
8. Adjust the diopter ring as necessary to ensure an in-focus image of the reticle.
9. Use the center of the reticle to aim the weapon at the target and fire 3-5 rounds.
10. After clearing the weapon, visually check the center of the shot grouping on the target.
11. Make adjustments as necessary to the azimuth and elevation reticles according to the table below.

Reticle Adjustment Per Click				
	-32M	-64M	-32L	-64L
100 yds	1.1”	1.5”	0.6”	0.9”

**Table 3-2 Reticle Adjustment Per Click**

12. Fire and adjust the reticles until the center of the shot grouping and the reticle are coincident.

### 3.17 Powering OFF the UTAC:

To power OFF the system perform the following:

1. Simultaneously press the Polarity (Menu Select) and Display Brightness (Scroll Down) buttons on the keypad. Visually check that the unit is inoperative by looking through the eyepiece.

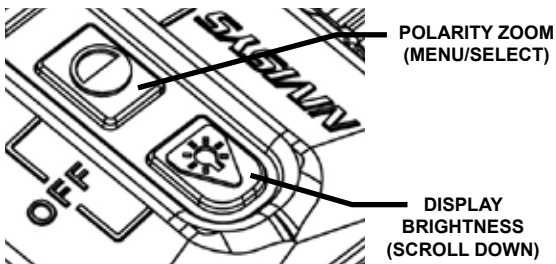

Figure 3-17 Powering OFF the UTAC

### 3.18 Preparation for Storage:

1. Remove batteries from the UTAC.
2. Inspect the battery housing for corrosion or moisture. Clean and dry if necessary.
3. Replace the battery cap.
4. Remove the demist shield if installed.
5. Install objective lens cover.

#### **NOTE**

**PRIOR TO PLACING UTAC INTO CARRYING CASE, ENSURE UTAC AND CASE ARE FREE OF DIRT, DUST, AND MOISTURE.**

6. Place the UTAC, accessories and cleaning supplies back into their storage/carrying cases. It is best to place the items in their original locations to prevent any possible damage to the unit and/or accessories.
7. Return to storage area.

### **3.19 Use with the RS-16 Remote Switch:**

The UTAC may be used with the supplied remote switch. When attached, all keypad functions of the UTAC, except for powering ON, can be executed using the remote switch.

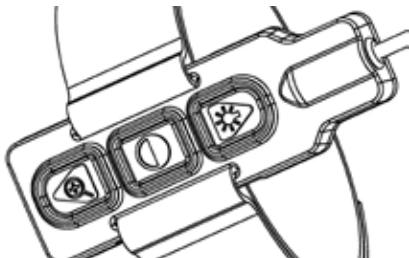

**Figure 3-18 Remote Switch**

# **CHAPTER 4:**

## **MAINTENANCE INSTRUCTIONS**

### **4.1 Introduction:**

The UTAC is designed to be used in diverse environments and rugged conditions. It is recommended that regular and simple maintenance is performed for optimal system performance.

### **CAUTION**

**THIS WEAPON SIGHT IS A PRECISION  
ELECTRO-OPTICAL INSTRUMENT AND MUST  
BE HANDLED CAREFULLY.**

**DO NOT SCRATCH THE EXTERNAL LENS  
SURFACES OR TOUCH THEM WITH YOUR  
FINGERS.**

**WIPING DEMIST SHIELD WITH LENS TISSUE  
WHILE WET OR WITH WET LENS TISSUE CAN  
DAMAGE THE COATING.**

### **4.2 Preparing for Maintenance:**

Before performing any maintenance or cleaning of the system, remove all power sources from the UTAC including batteries and/or external power supplies.

### **4.3 Cleaning the UTAC:**

When necessary, use a moistened clean cloth to wipe the outside of the unit, **EXCEPT FOR THE OPTICAL SURFACES**. Be sure to wipe away excess dirt and dust that may restrict the performance or damage moving and mating parts. If needed, the use of a very diluted detergent solution is permissible. Dry with a soft clean cloth, or allow unit to air-dry before storing it.

#### **4.4 Cleaning the Optics:**

When cleaning of the lens is required, first blow any loose dirt or grit away from the surface of the lens. Use the supplied lens tissue, lightly moistened with water or lens cleaning fluid to lightly wipe the optical surfaces, using a circular motion. Discard each lens tissue after one use to avoid transferring grit or foreign matter onto the lens surfaces. If the lens remains dirty, use a cotton swab lightly moistened with lens cleaning fluid to remove the foreign matter from the lens. Dry with a clean unused lens tissue.

#### **4.5 Checking for Damage and Corrosion:**

As a general guideline, conduct an inspection of the UTAC, accessories, and the case after every use. Look for heavy wear and cracks in rubber or plastic. Inspect for moisture or corrosion in the battery compartment. Check for scratches, condensation and foreign matter on optical surfaces. Report missing or damaged items, for replacement.

# CHAPTER 5: TROUBLESHOOTING

## 5.1 Troubleshooting Procedures:

Table 5-1 lists common malfunctions that may occur with the equipment. Perform the tests, inspections and corrective actions in the order they appear in the table.

This table cannot list all the malfunctions that may occur, all the tests and inspections needed to find the fault, or all the corrective actions needed to correct the fault. If the equipment malfunction is not listed or actions listed do not correct the fault, notify your maintainer.

<b>Malfunction</b>	<b>Test or Inspection</b>	<b>Corrective Action</b>
Unit fails to power ON.	Visual.  Check for defective, missing or improperly installed battery.	Power OFF the system and then ON.  Replace battery or install correctly.  Tighten battery cap until the orange o-ring is no longer visible.  If UTAC still fails to power ON, refer to higher level of maintenance.

**Table 5-1 Troubleshooting**

Flickering Image on firing.	Check for loose battery cap that may cause the battery to lose contact during weapon fire.	Tighten battery cap until the orange o-ring is no longer visible.
No display in eyepiece.	Visual check to see if lens cover is still on.	Flip lens cover open.
Poor image quality.	Check for fogging or dirt on objective lens or collimation lens.  Visual.	Clean optics.  Adjust Range Focus. (On -64L and -32L only)
Light visible around hood.	Check hood for resiliency.	If hood is defective, refer to higher level of maintenance.
Optics hard to turn or grinding.	Check for dirt or debris on traveling eyepiece cell.  Check to see if the diopter adjustment is bent or broken.	Clean with a soft dry cloth.  If damaged, refer to higher level of maintenance.

**Table 5-1 Troubleshooting, (cont.)**

<p>Remote Switch keypad not working.</p>	<p>Check to ensure connectors are free from debris, dirt and corrosion.</p> <p>Check to ensure hot shoe connector is completely installed into unit.</p>	<p>Firmly push connector into mating connector on UTAC unit and tighten thumbscrew.</p> <p>Clean connectors.</p> <p>If remote switch keypad is still not working, refer to higher level of maintenance.</p>
<p>Will not zero.</p>	<p>Check to see if UTAC is securely fastened to weapon mount.</p> <p>Check to see that weapon mount is correctly and securely fastened to weapon.</p> <p>Check to see if zeroing is being done in digital zoom mode.</p> <p>Check to see if mount adapter rail is loose or missing fasteners.</p>	<p>Tighten the weapon mount to the UTAC.</p> <p>Correctly and securely fasten to weapon mount to weapon.</p> <p>Press the digital zoom button to enter digital zoom mode when zeroing.</p> <p>Replace screws and/or tighten with appropriate driver.</p> <p>If problem persists, refer to higher level of maintenance.</p>

**Table 5-1 Troubleshooting, (cont.)**

**This page intentionally left blank.**

# APPENDIX A: SPARE AND REPAIR PARTS LIST

## A.1 Introduction:

This section provides information needed to identify, contact and order spare and/or repair parts for the UTAC.

## A.2 Contact Information:

To order spare or repair parts for the UTAC or any other night vision products contact:

Nivisys Industries, L.L.C.  
400 S. Clark Drive, Suite #105  
Tempe, Arizona 85281 USA

Phone: 1-480-970-3222

Fax: 1-480-970-3555

Nivisys Industries GSA #: GS-07F-6054P

## A.3 Spare Parts List:

The following is a list of parts that may be ordered as spares for the UTAC.

Part No.	Description	Qty.
7B257-2F	Shipping/Storage Case	1
830-0079-0	Operator Manual, UTAC Series	1
830-0089-0	Quick Reference Guide, UTAC Series	1
830-0057-0	Quick Reference Guide, RS-16	1
4200-900	Single Throw Lever Mount	1

**Table A-1 Spare and Repair Parts List**

790-0015-0	Mount Adjustment Tool	1
310-0024-0	Mount Adapter, V-Block	1
3250-000	RS-16 (Remote Switch, 16")	1
3251-000	RS-24 (Remote Switch, 24")	1
1407-500	Soft Carrying Case	1
1407-501	Shoulder Strap	1
580-0002-0	Battery, CR123 Lithium (2ea. required for operation)	1
170-12	Cleaning Kit	1
4200-404	Coupling Hood	1
A3144306	Neck Cord	1
A3144315	Purge Screw	1
A3144316	Purge Screw O-Ring	1
3200-600	Battery Cap	1
784-0025-A	O-Ring, Battery Cap	1
3200-112	Hot Shoe Dust Cover	1
640-0003-0	Hook and Loop Tape, 16in	1
4200-800	35mm Lens Cover Replacement Kit	1
220-0013-0	60mm Lens Cover	1

**Table A-1 Spare and Repair Parts List, (cont.)**

## **APPENDIX B: WARRANTY INFORMATION**

### **Equipment Warranties And Remedy:**

Seller warrants that each newly manufactured item sold hereunder and such portion of a repaired/refurbished item as has been repaired or replaced by Seller under this warranty, shall be free from defects in material or workmanship at the time of shipment and shall perform during the warranty period in accordance with the specifications incorporated herein. Should any failure to conform to these warranties be discovered and brought to Seller's attention during the warranty period and be substantiated by examination at Seller's factory or by authorized field personnel, then at its own cost, Seller shall correct such failure by, at Seller's option, repair or replacement of the non-conforming item or portion thereof, or return the unit purchase price of the non-conforming item or component. Buyer agrees that this remedy shall be its sole and exclusive remedy against Seller and that no other remedy shall be available or pursued by Buyer against Seller. In no event shall the Seller be liable for any cost or expense in excess of those described in this paragraph and expressly excluding any liability or damages for special, incidental or consequential damages.

The warranty period for newly-manufactured items shall extend 12 months from the date of shipment by Seller unless a different warranty period is agreed in writing to by Seller. The warranty period for repaired/refurbished electronic components shall extend for the unexpired warranty period or 90 days, whichever is longer, of the item repaired or replaced.

This warranty shall not extend to any item that upon examination by Seller is found to have been subject to:

- A. Mishandling, misuse, negligence or accident.

- B. Installation, operation or maintenance that either was not in accordance with Seller's specifications and instructions, or otherwise improper.
- C. Tampering, as evidenced, for example, by broken seals, damaged packaging containers, etc.
- D. Repair or alteration by anyone other than Seller without Seller's express advance written approval.

Failure to promptly notify Seller in writing upon discovery of any non-conforming item during the warranty period shall void the warranty as to such item. Buyer shall describe any such non-conformity in detail, expressing its position as to return of any article under the remedy provided herein. No returns shall be accepted without prior approval by Seller, who shall arrange for transportation. The cost of transportation for articles returned to Seller and/or redelivered to Buyer shall be paid by Seller only if Seller is responsible for repair or replacement under this warranty. In the event the item is found to conform to the specifications and requirements of this order, the transportation charges related to the return and re-delivery thereof are for the account of Buyer.

**Return Material Authorization Number (RMA#):**

Warranty and non-warranty items returned to Nivisys for repair or replacement require a RMA#. Email [support@nivisys.com](mailto:support@nivisys.com), call 1-480-970-3222 or fax 1-480-970-3555 with a serial number and detailed information to obtain a RMA#.

**THIS WARRANTY IS EXCLUSIVE AND IN LIEU OF ANY OTHER WARRANTY, EITHER EXPRESSED OR IMPLIED, INCLUDING WARRANTIES OF MERCHANTABILITY OR FITNESS FOR A PARTICULAR PURPOSE.**

**Inside cover intentionally left blank.**



Nivisys Industries, LLC  
400 S. Clark Drive, Suite 105  
Tempe, Arizona 85281 USA

[nivisys.com](http://nivisys.com)